

***Calkins***

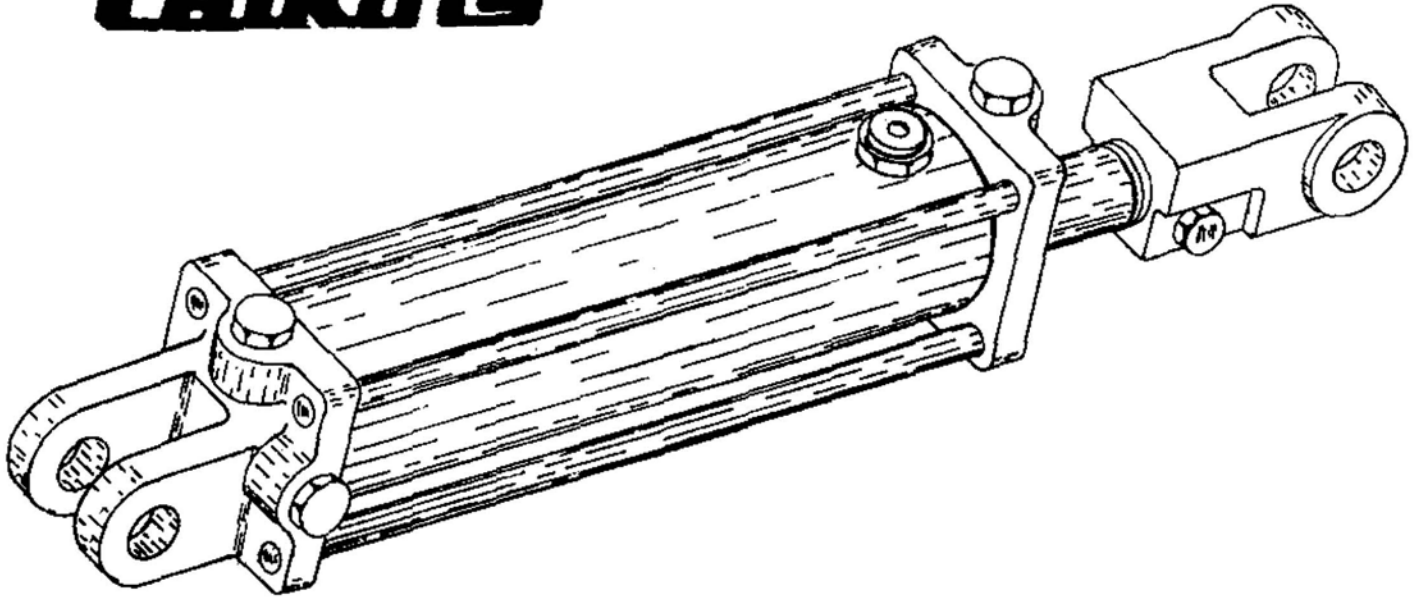

Hydraulic Cylinder  
And  
Replacement Parts Manual

**J.E. LOVE COMPANY**  
**LOVE**®

309 W. CALIFORNIA STREET  
P.O. BOX 188  
GARFIELD, WASHINGTON 99130-0188  
(509) 635-1321 FAX: (509) 635-1434  
[www.jeloveco.com](http://www.jeloveco.com)

PRINTED IN U.S.A.

# CYLINDER PARTS LIST

The purpose of this book is to provide general guidelines to cylinders and their replacement parts for machinery built between 1978 and the present. Approximate dates are intended to assist in pinpointing the cylinder used, but it is strongly recommended to obtain the manufacturer's part number from the cylinder wherever possible. Replacement parts for these cylinders are often special order and may not be returnable. If no label is present, the manufacturer's part number is usually etched into the barrel of the cylinder. The detail shown on the following page will help illustrate the key differences between models.

All parts are subject to availability.

## **R/S Series Cylinders, 1978 through July 1988**

The cylinders had an *internal* bypass. It is recommended that the poppet and seat be replaced when installing a new seal kit. These cylinders are visibly different from the newer rephase cylinders, which have an external bypass.

## **AB Series Cylinders, 1988 through 1990**

These cylinders had a bypass or rephase port on the *outside* of the barrel. The piston had a single bearing ring near the rear of the piston, and the teflon seal and o-ring loader were located near the front. The rod seal package consisted of a u-cup and snap-in (single lip) wiper.

## **AF Series Cylinders, 1990 through 1993**

These are externally identical to the AB series cylinders. The teflon seal was located in the center of the piston, and there were two bearing rings, one near the front and one near the rear of the piston. A metal clad wiper replaced the snap-in wiper on the AB series cylinders.

## **AM Series Cylinders, 1993 to Present**

These cylinders featured notched bearing rings on the piston and a DU bushing in the gland. The rods were undersized about .004" to provide running clearance for the DU bushing. The rod seal was upgraded to an o-ring loaded u-cup.

The suffix "A" was added to the 3-3/4" and 4" bore models in 1997. The thread on the rod and clevis for these cylinders was increased to 1-5/16". All other replacement parts remain the same.

The suffix "N" was added in 1999, and indicated an improvement in the plating on the piston rod. This designation does not affect the ordering of replacement parts.

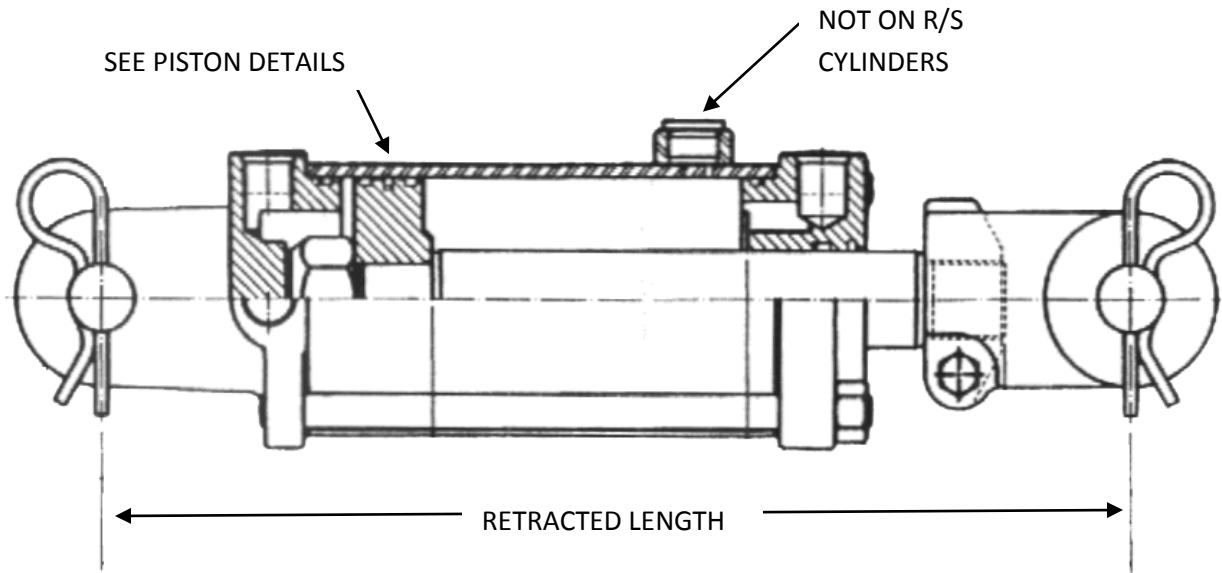

PISTON DETAILS

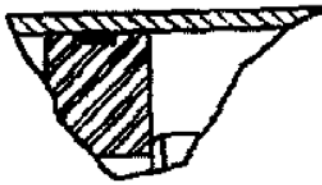

R/S SERIES

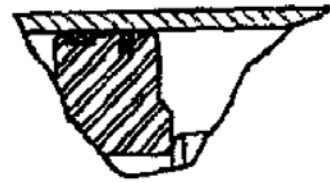

AB SERIES

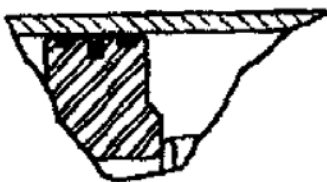

AF SERIES



AM SERIES

## CYLINDER PARTS LIST

### **R/S SERIES CYLINDERS**

**8" STROKE**      *20-1/4" RETRACTED LENGTH*

<b>PART#</b>	<b>5818-032</b>	<b>5818-035</b>	<b>5818-037</b>	<b>5818-037</b>	<b>5818-040</b>	<b>5818-045</b>	<b>5818-047</b>	<b>5818-050</b>
<b>MFG#</b>	<b>R-610</b>	<b>S-427</b>	<b>S-1451</b>	<b>R-608</b>	<b>S-422</b>	<b>P-1135</b>	<b>P-1134</b>	<b>S-418</b>
<b>BORE</b>	3 1/4	3 1/2	3 3/4	3 3/4	4	4 1/2	4 3/4	5
<b>PISTON ROD</b>	010400004	010600004	010700272	010700157	010800006	011100292	010800191	010800197
<b>ROD DIA.</b>	1-1/4"	1-1/4"	1-3/8"	1-3/8"	1-1/2"	2"	1-1/2"	1-1/2"
<b>TUBE</b>	051600006	051700009	141800008	051800007	051900008	052000016	052100268	052100295
<b>GLAND</b>	081600005	081700106	081800004	081800004	081900123	082000013	082100099	082100109
<b>PISTON</b>	071600005	071700064	071800008	071800003	071900111	072000011	072100095	072100094
<b>TIE ROD</b>	170201121	170201121	170301131	170301133	170301133	170301136	170301136	170301136
<b>BUTT</b>	141600001	141700021	141800008	141800001	141900030	142000001	142100010	142100013
<b>CLEVIS</b>	100000018	100000018	100000066	100000066	100000043	100000043	100000043	100000043
<b>POPPET</b>	180900223	180900223	180900223	180900223	180900223	180900223	180900223	180900223
<b>SEAT</b>	180900225	180900225	180900225	180900225	180900225	180900225	180900225	180900225
<b>SEAL KIT</b>	5899-052	5899-058	5899-051	5899-051	5899-057	5899-056	5899-055	5899-054

## CYLINDER PARTS LIST

**R/S SERIES, cont'd**

**12" STROKE    24-1/4" RETRACTED LENGTH**

<b>PART#</b>	<b>5818-443</b>	<b>5818-442</b>	<b>5818-441</b>	<b>5818-441</b>	<b>5818-440</b>	<b>5818-444</b>
<b>MFG#</b>	<b>S-430</b>	<b>S-428</b>	<b>S-425</b>	<b>S-1452</b>	<b>S-423</b>	<b>R-1307</b>
<b>BORE</b>	<i>3-1/4</i>	<i>3-1/2</i>	<i>3-3/4</i>	<i>3-3/4</i>	<i>4</i>	<i>4-1/2</i>
<b>PISTON ROD</b>	010600007	010600007	010700172	010700273	010800008	011100301
<b>ROD DIA.</b>	<i>1-1/4"</i>	<i>1-1/4"</i>	<i>1-3/8"</i>	<i>1-3/8"</i>	<i>1-1/2"</i>	<i>2"</i>
<b>TUBE</b>	051600008	051700011	051800010	051800010	051900010	052000018
<b>GLAND</b>	081600005	081700106	081800004	081800004	081900123	082000013
<b>PISTON</b>	071600005	071700064	071800003	071800003	071900111	072000011
<b>TIE ROD</b>	170201161	170201161	170301173	170301173	170301173	170301176
<b>BUTT</b>	141600001	141700021	141800001	141800008	141900030	142000001
<b>CLEVIS</b>	100000018	100000018	100000066	100000066	100000043	100000043
<b>POPPET</b>	180900223	180900223	180000301	180000301	180000301	180900223
<b>SEAT</b>	180900225	180900225	180000303	180000303	180000303	180900225
<b>SEAL KIT</b>	5899-063	5899-062	5899-060	5899-060	5899-059	5899-071

### Wing Lift Cylinders

<b>PART#</b>	<b>5818-481</b>	<b>5818-580</b>	<b>5818-510</b>
<b>MFG#</b>	<b>S-509</b>	<b>S-512</b>	<b>S-511</b>
<b>BORE</b>	<i>4</i>	<i>5</i>	<i>5</i>
<b>STROKE</b>	<i>24</i>	<i>24</i>	<i>30</i>
<b>PISTON ROD</b>	010800220	010800223	010800222
<b>TUBE</b>	051900015	052100017	052100018
<b>GLAND</b>	081900006	082100108	082100108
<b>PISTON</b>	071900006	072100104	072100104
<b>TIE ROD</b>	170301293	170301295	170301355
<b>BUTT</b>	141900006	142100012	142100012
<b>CLEVIS</b>	100000326	100000326	100000326
<b>SEAL KIT</b>	5899-065	5899-067	5899-066

## CYLINDER PARTS LIST

### AB SERIES CYLINDERS

**8" STROKE**      *20-1/4" RETRACTED LENGTH*

<b>PART#</b>	<b>5818-055</b>	<b>5818-056</b>	<b>5818-057</b>	<b>5818-058</b>	<b>5818-059</b>	<b>5818-060</b>	<b>5818-061</b>
<b>MFG#</b>	<b>AB-1268</b>	<b>AB-1262</b>	<b>AB-1256</b>	<b>AB-1250</b>	<b>AB-1244</b>	<b>AB-1238</b>	<b>AB-1232</b>
<b>BORE</b>	3 1/4	3 1/2	3 3/4	4	4 1/2	4 3/4	5
<b>PISTON ROD</b>	010600165	010600164	010700267	010700267	011100292	010800197	010800197
<b>ROD DIA.</b>	1-1/4"	1-1/4"	1-3/8"	1-3/8"	2"	1-1/2"	1-1/2"
<b>TUBE</b>	061600019	061700306	061800013	061900465	062000052	062100405	062100403
<b>GLAND</b>	081600020	081700242	081800018	081900237	082000047	082100199	082100206
<b>PISTON</b>	071600017	071700131	071800011	071900181	072000048	072100160	072100159
<b>TIE ROD</b>	170201121	170201121	170301132	170301132	170301135	170301135	170301135
<b>BUTT</b>	141600002	141700023	141800009	141900037	142000004	142100019	142100020
<b>CLEVIS</b>	100000018	100000423	100000330	100000330	100000326	100000326	100000326
<b>SEAL KIT</b>	5899-087	5899-088	5899-089	5899-090	5899-086	5899-085	5899-084

**12" STROKE**      *24-1/4" RETRACTED LENGTH*

<b>PART#</b>	<b>5818-062</b>	<b>5818-063</b>	<b>5818-064</b>	<b>5818-065</b>	<b>5818-066</b>
<b>MFG#</b>	<b>AB-1270</b>	<b>AB-1264</b>	<b>AB-1258</b>	<b>AB-1252</b>	<b>AB-1246</b>
<b>BORE</b>	3-1/4	3-1/2	3-3/4	4	4-1/2
<b>PISTON ROD</b>	010600200	010600199	010700358	010700358	011100505
<b>ROD DIA.</b>	1-1/4"	1-1/4"	1-3/8"	1-3/8"	2"
<b>TUBE</b>	061600022	061700347	061800017	061900517	062000055
<b>GLAND</b>	081600020	081700188	081800012	081900237	082000047
<b>PISTON</b>	071600017	071700131	071800011	071900181	072000048
<b>TIE ROD</b>	170201161	170201161	170301172	170301172	170301175
<b>BUTT</b>	141600002	141700023	141800009	141900037	142000004
<b>CLEVIS</b>	100000018	100000018	100000330	100000330	100000326
<b>SEAL KIT</b>	5899-083	5899-072	5899-074	5899-073	5899-076

## CYLINDER PARTS LIST

### AF SERIES CYLINDERS

**8" STROKE**      *20-1/4" RETRACTED LENGTH*

<b>PART#</b>	<b>5818-055</b>	<b>5818-056</b>	<b>5818-057</b>	<b>5818-058</b>	<b>5818-059</b>	<b>5818-060</b>	<b>5818-061</b>
<b>MFG#</b>	<b>AF-1068</b>	<b>AF-1062</b>	<b>AF-1056</b>	<b>AF-1050</b>	<b>AF-1044</b>	<b>AF-1038</b>	<b>AF-1032</b>
<b>BORE</b>	<i>3 1/4</i>	<i>3 1/2</i>	<i>3 3/4</i>	<i>4</i>	<i>4 1/2</i>	<i>4 3/4</i>	<i>5</i>
<b>PISTON ROD</b>	010600165	010600164	010700267	010700267	011100292	010800197	010800197
<b>ROD DIA.</b>	<i>1-1/4"</i>	<i>1-1/4"</i>	<i>1-3/8"</i>	<i>1-3/8"</i>	<i>2"</i>	<i>1-1/2"</i>	<i>1-1/2"</i>
<b>TUBE</b>	061600036	061700397	061800021	061900579	062000079	062100544	062100545
<b>GLAND</b>	081600031	081700242	081800018	081900336	082000043	082100263	082100270
<b>PISTON</b>	071600019	071700157	071800016	071900226	072000072	072100216	072100217
<b>TIE ROD</b>	170201121	170201121	170301132	170301132	170301135	170301135	170301135
<b>BUTT</b>	141600002	141700023	141800009	141900037	142000004	142100019	142100020
<b>CLEVIS</b>	100000423	100000423	100000330	100000330	100000326	100000326	100000326
<b>SEAL KIT</b>	5899-120	5899-125	5899-130	5899-135	5899-140	5899-145	5899-150

**12" STROKE**      *24-1/4" RETRACTED LENGTH*

<b>PART#</b>	<b>5818-062</b>	<b>5818-063</b>	<b>5818-064</b>	<b>5818-065</b>	<b>5818-066</b>
<b>MFG#</b>	<b>AF-1070</b>	<b>AF-1064</b>	<b>AF-1058</b>	<b>AF-1052</b>	<b>AF-1046</b>
<b>BORE</b>	<i>3-1/4</i>	<i>3-1/2</i>	<i>3-3/4</i>	<i>4</i>	<i>4-1/2</i>
<b>PISTON ROD</b>	010600200	010600199	010700358	010700358	011100505
<b>ROD DIA.</b>	<i>1-1/4"</i>	<i>1-1/4"</i>	<i>1-3/8"</i>	<i>1-3/8"</i>	<i>2"</i>
<b>TUBE</b>	061600028	061700366	061800022	061900598	062000080
<b>GLAND</b>	081600031	081700242	081800018	081900336	082000073
<b>PISTON</b>	071600019	071700157	071800016	071900226	072000072
<b>TIE ROD</b>	170201161	170201161	170301172	170301172	170301175
<b>BUTT</b>	141600002	141700023	141800009	141900037	142000004
<b>CLEVIS</b>	100000423	100000423	100000330	100000330	100000326
<b>SEAL KIT</b>	5899-155	5899-160	5899-165	5899-170	5899-175

## CYLINDER PARTS LIST

**AM SERIES**  
**8" STROKE**

*20-1/4" RETRACTED LENGTH*

<b>PART#</b>	<b>5819-054</b>	<b>5819-055</b>	<b>5819-056</b>	<b>5819-057</b>	<b>5819-058</b>	<b>5819-059</b>	<b>5819-060</b>	<b>5819-061</b>
<b>MFG#</b>	<b>AM-2574</b>	<b>AM-2568</b>	<b>AM-2562</b>	<b>AM-2556*</b>	<b>AM-2550*</b>	<b>AM-2544</b>	<b>AM-2538</b>	<b>AM-2532</b>
<b>BORE</b>	3	3 1/4	3 1/2	3 3/4	4	4 1/2	4 3/4	5
<b>PISTON ROD</b>	010600382	010600382	010600382	010700560	010700560	011100732	010800648	010800648
<b>ROD DIA</b>	1.246"	1.246"	1.246"	1.371"	1.371"	1.996"	1.496"	1.496"
<b>TUBE</b>	061500488	061600036	061700397	061800021	061900579	062000079	062100544	062100545
<b>GLAND</b>	081500337	081600038	081700269	081800022	081900374	082000092	082100284	082100293
<b>PISTON</b>	071500267	071600025	071700208	071800021	071900273	072000097	072100244	072100245
<b>TIE ROD</b>	170201121	170201121	170201121	170301132	170301132	170301135	170301135	170301135
<b>BUTT</b>	141500043	141600002	141700023	141800009	141900037	142000004	142100019	142100020
<b>CLEVIS</b>	100000423	100000423	100000423	100000330	100000330	100000326	100000326	100000326
<b>SEAL KIT</b>	5899-180	5899-185	5899-190	5899-195	5899-200	5899-205	5899-210	5899-215

\* Piston rods were changed on these models indicated with a suffix "A" in 1997. The Piston Rod for the AM2556A and AM-2550A is Part # 010700696, and the Clevis is Part # 100000577. The thread diameter was increased from 1-1/8" to 1-5/16" on these models.



## CYLINDER PARTS LIST

### **AM SERIES, Cont'd**

**12" STROKE**    *24-1/4 RETRACTED LENGTH*

<b>PART#</b>	<b>5819-062</b>	<b>5819-063</b>	<b>5819-064</b>	<b>5819-065</b>	<b>5819-066</b>
<b>MFG#</b>	<b>AM-2570</b>	<b>AM-2564</b>	<b>AM-2558*</b>	<b>AM-2552*</b>	<b>AM-2546</b>
<b>BORE</b>	<i>3-1/4</i>	<i>3-1/2</i>	<i>3-3/4</i>	<i>4</i>	<i>4-1/2</i>
<b>PISTON ROD</b>	010600379	010600379	010700561	010700561	011100737
<b>ROD DIA.</b>	1.246"	1.246"	1.371"	1.371"	1.996"
<b>TUBE</b>	061600028	061700366	061800022	061900598	062000080
<b>GLAND</b>	081600038	081700269	081800022	081900374	082000092
<b>PISTON</b>	071600025	071700208	071800021	071900273	072000097
<b>TIE ROD</b>	170201161	170201161	170301172	170301172	170301175
<b>BUTT</b>	141600002	141700023	141800009	141900037	142000004
<b>CLEVIS</b>	100000423	100000423	100000330	100000330	100000326
<b>SEAL KIT</b>	5899-220	5899-225	5899-230	5899-235	5899-240

\* Piston rods were changed on these models indicated with a suffix "A" in 1997. The Piston Rod for the AM2552A and AM-2558A is Part # 010700698, and the Clevis is Part # 100000577. The thread diameter was increased from 1-1/8" to 1-5/16" on these models.

## CYLINDER PARTS LIST

**AJ SERIES**      **(Wing Lift)**

*1988 to Present*

<b>PART#</b>	<b>5818-605</b>	<b>5818-610</b>	<b>5818-615</b>
<b>MFG#</b>	<b>AJ-16</b>	<b>AJ-17</b>	<b>AJ-18</b>
<b>BORE</b>	4	5	5
<b>STROKE</b>	24	24	30
<b>ROD DIA</b>	1-1/2"	1-1/2"	1-1/2"
<b>RET. LENGTH</b>	36-1/4"	36-1/4"	42-1/4"
<b>PISTON ROD</b>	010800220	010800223	010800222
<b>TUBE</b>	051900015	052100017	052100018
<b>GLAND</b>	081900231	082100206	082100206
<b>PISTON</b>	071900006	072100104	072100104
<b>TIE ROD</b>	170301293	170301295	170301355
<b>BUTT</b>	141900037	142100020	142100020
<b>CLEVIS</b>	100000326	100000326	100000326
<b>SEAL KIT</b>	5899-096	5899-097	5899-097